

Litesphere Adapt 2.0 Installation Instructions



Warnings and Safety

- Please verify the contents of the package!
- Please read instructions before starting the installation.
- Make sure the power is off before installing or modifying the system.
- Call Tivoli LLC tech support with any questions.
- This product is designed to work with listed Class 2, 12V DC transformers only. Use of any other power source will cause damage, shorten the life of the fixture, and will void the warranty.
- Consult any local and national codes for installation.
- Follow basic safety precautions when dealing with any luminaire application to reduce the risk of fire, electrical shock, and/or personal injuries. This lighting system should be installed by a certified professional.

- **Do not** use this product for other than its intended use.
- **Do not** cover any luminaire as the covering may cause it to overheat.
- **Do not** install this lighting system where the exposed bare contacts can be shorted or contact any conductive material to reduce the risk of fire and burns.
- **Do not** install any luminaire closer than 6 inches (15.25cm) from any curtain, or similar combustible material.
- **Do not** use any luminaire if damaged, such as a broken globe, loose connections, or frayed wire insulation. Inspect periodically.
- **Do not** submerge any luminaire in liquid. Use waterproof connectors for all outdoor applications.
- **Do not** secure any luminaire with staples, nails or like means that might damage the wire insulation. Secure it by using screws through the base.
- **Do not** run any luminaire at an operating temperature exceeding 65° C or 149° F.
- **Do not** let lamps rest on any wires.
- **Do not** hang objects from light string wires or extension cord.
- **Do not** route Light String through walls, doorways, windows or building structures. Do not close doors or windows on product wire as damage will result.
- **Do not** cover lamps with cloth, paper or any material that is not part of the product.
- **Do not** install in enclosed spaces, such as soffits, cabinets or in ceilings.

Litesphere Adapt 2.0 Installation Instructions



Surface Mount Installation

1. Remove the socket cap and secure the socket cap to the mounting surface using the appropriate screws. Repeat for each socket.

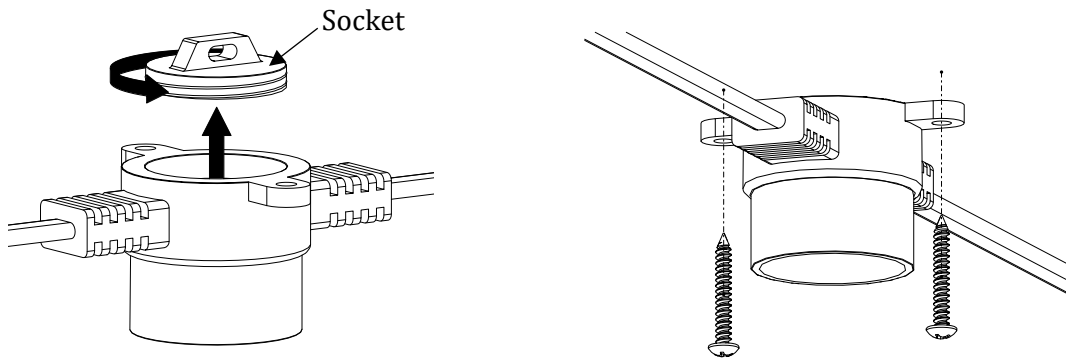

Suspended Installation

1. Attach eyebolts or other mounting hardware to the structural supports that will hold the catenary cable.
 - a. The catenary cable is rated for hanging loads up to 200 lbs. and 800 lbs. of pulling tension.
2. Insert suspension cable into the cable following the direction of the arrow on the cable lock.
3. Loop the suspension cable through the mounted eye bolt or other mounting hardware and insert the cable back through the cable lock.

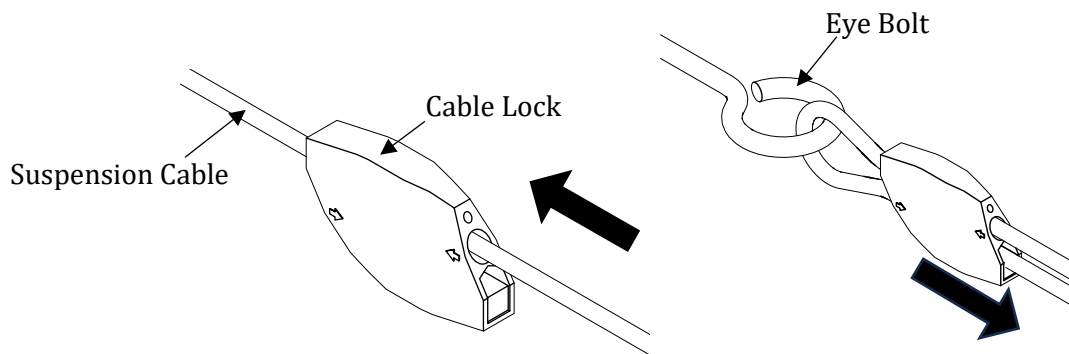

4. Tighten the suspension cable using a catenary tensioning tool or loosen the suspension cable using a cable release key on the cable lock.

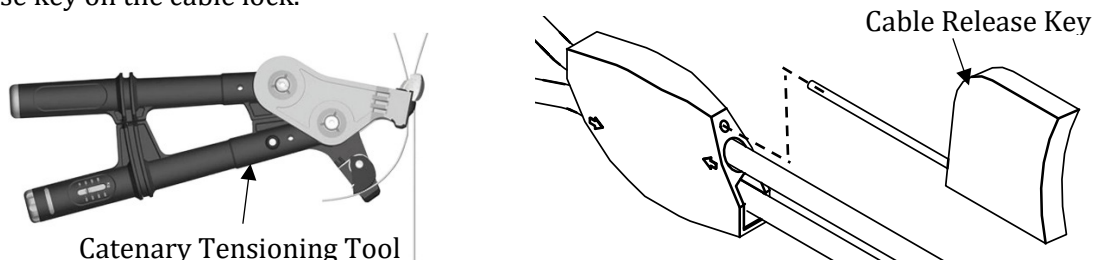

Litesphere Adapt 2.0 Installation Instructions



5. Attach the strands with the sockets to the suspension cable using zip ties.

NOTE: For strands with on center spacing of 18 in. or greater, use a zip in between globes to prevent sagging

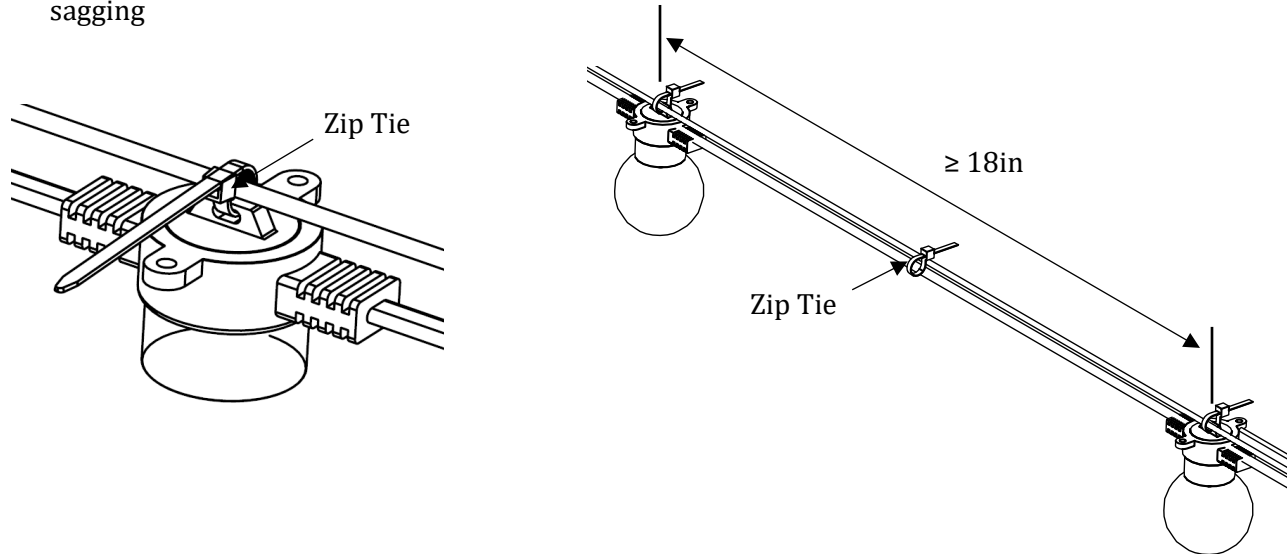

Optional: Create Shade Assembly

1. Create the shade assembly by placing the shade in between the gasket/globe and nut. Tighten the assembly.

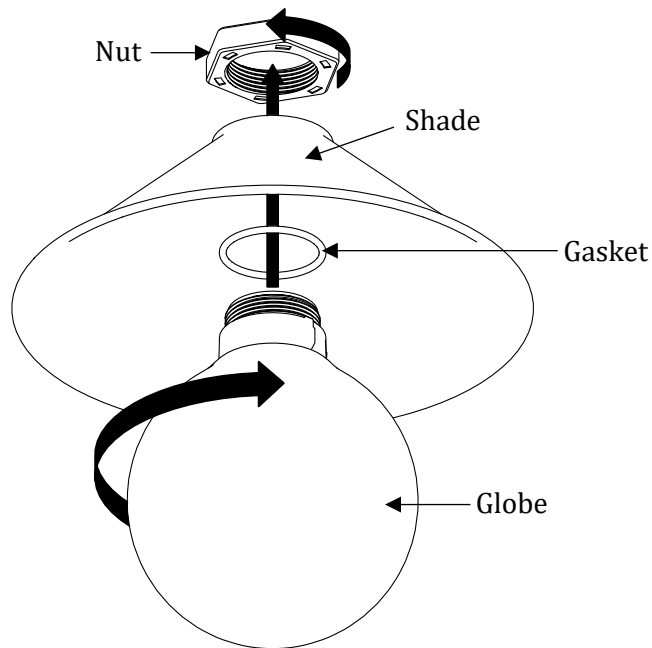

Litesphere Adapt 2.0 Installation Instructions



Globe Installation

1. Remove the plastic cover from the socket.

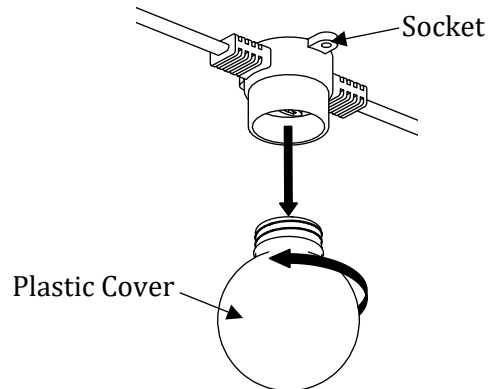

2. Attach the globe or the shade assembly to the socket.

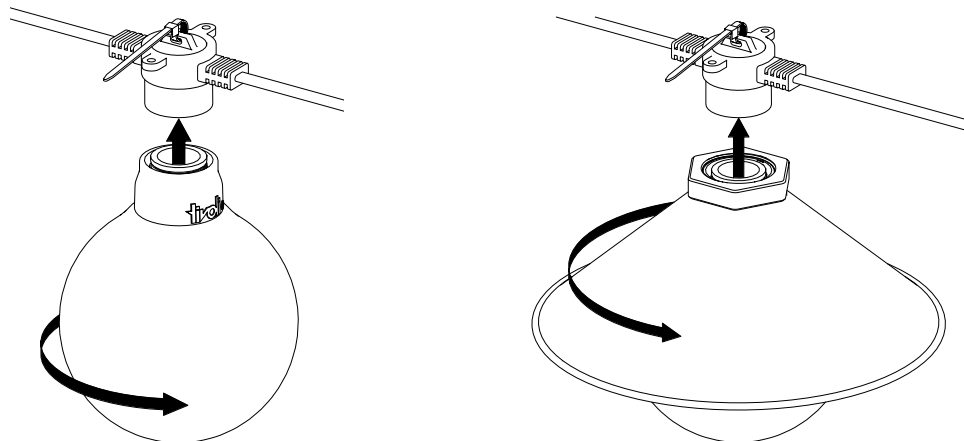

NOTE: To guarantee a proper fit and prevent potential issues, it is crucial to confirm that the gasket has been properly seated and positioned, and ensure it is not bent.

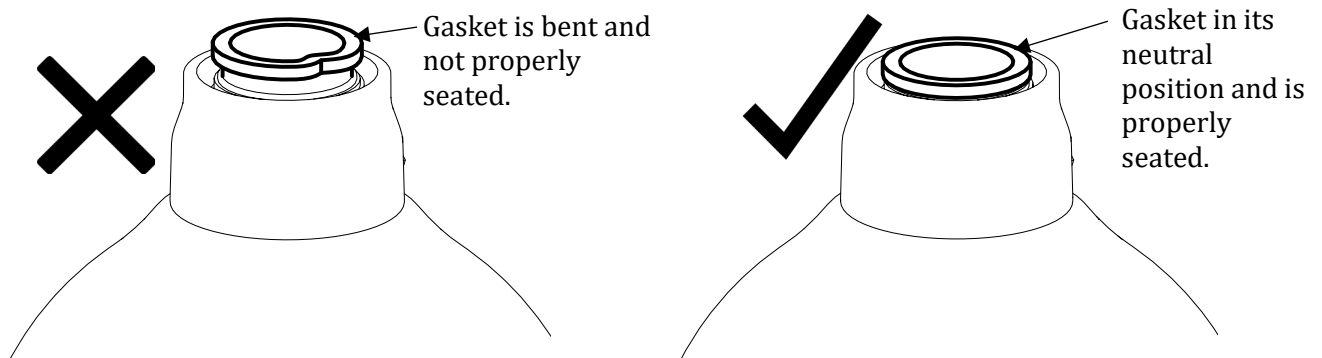

Litesphere Adapt 2.0 Installation Instructions



End Prep

1. At the end of the strand, cut 3 inches or more after the last globe to prepare to install the end cap.

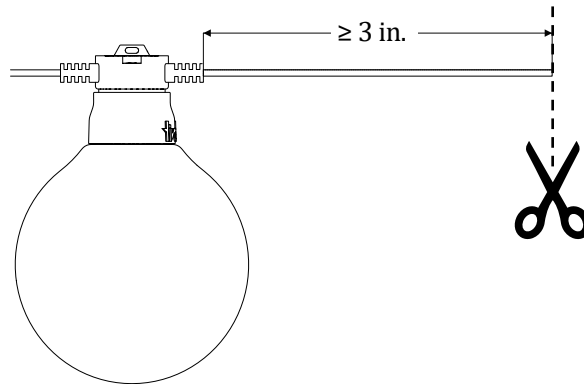

2. Loosen the end cap assembly and slide the base on the wire.

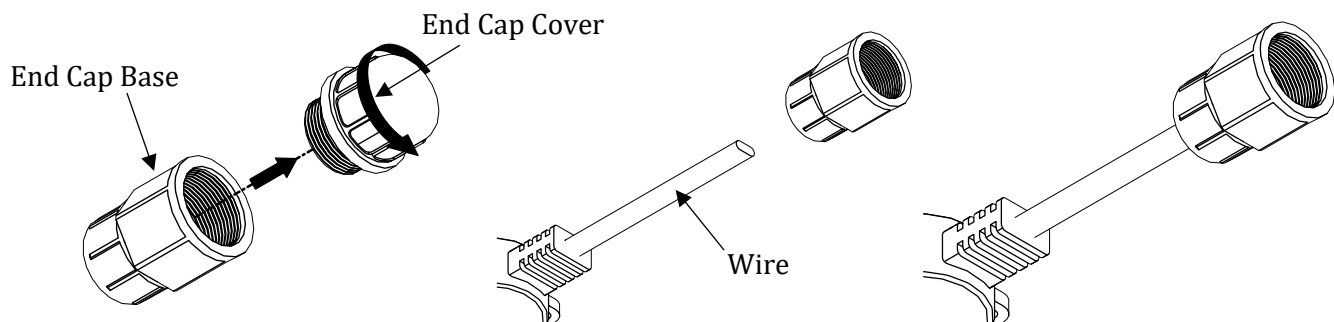

3. Attach the end cap cover onto the end cap base and tighten.

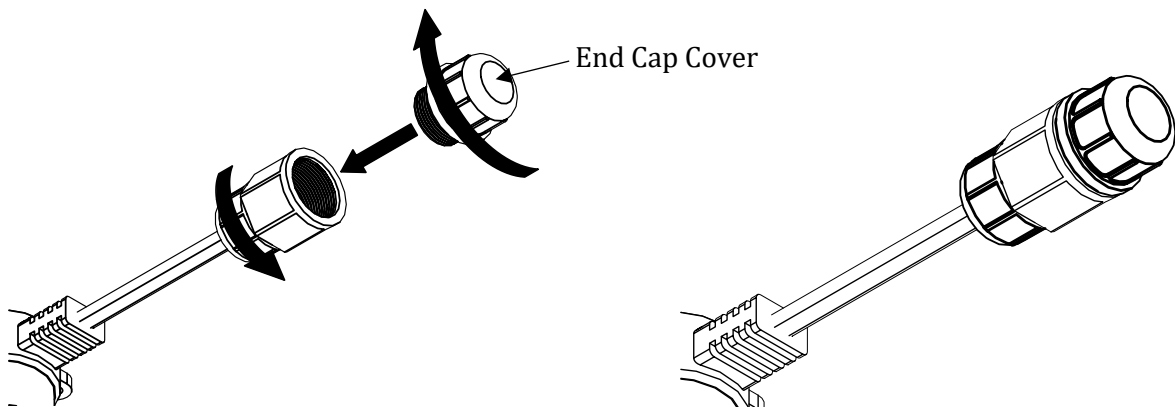

Litesphere Adapt 2.0 Installation Instructions



Wire Diagram

1. Connect to 12V DC power supply.

NOTE: Refer to related power supply specification sheets for more information and other possible configurations.

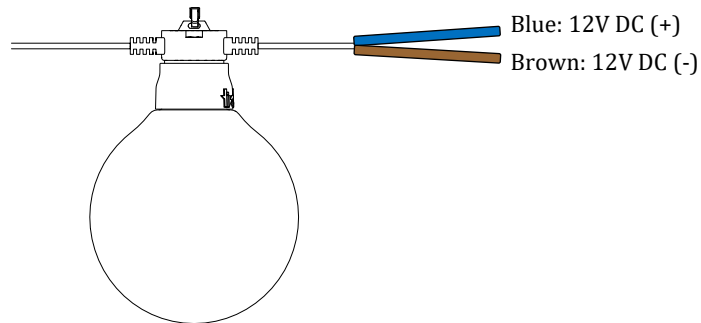

LED Replacement

1. Remove the globe and then remove the LED from the socket.

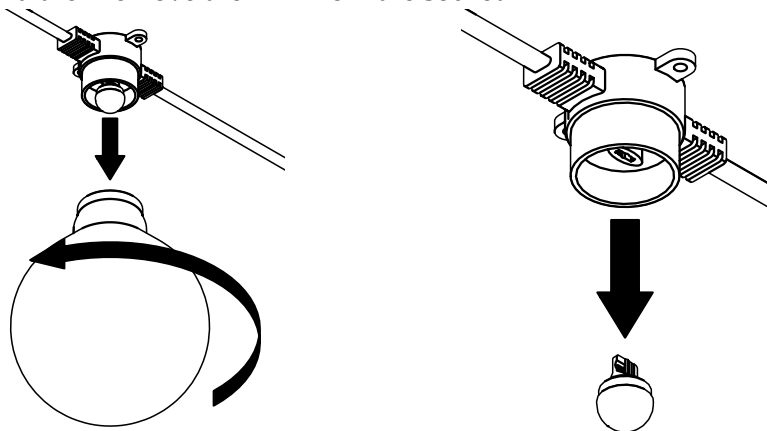

2. Insert the replacement LED and insert it into the socket. Turn on the fixture to confirm the LED lights up and then reattach the globe. If it does not light up, rotate the replacement LED 180 degrees and reinsert it back into the socket. Confirm that the replacement LED turns on, then reattach the globe.

